

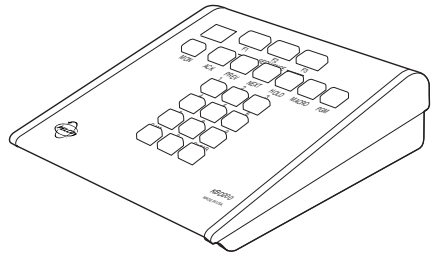

# Installation/Operation

## **KBD100 Universal Keyboard**

**C529M-D (9/03)**



**Pelco** • 3500 Pelco Way • Clovis, CA 93612-5699 USA • [www.pelco.com](http://www.pelco.com)

In North America and Canada: Tel (800) 289-9100 • FAX (800) 289-9150

International Customers: Tel +1(559) 292-1981 • FAX +1(559) 348-1120

## CONTENTS

REGULATORY NOTICES .....	2
IMPORTANT SAFEGUARDS AND WARNINGS .....	3
DESCRIPTION .....	3
INSTALLATION .....	4
Connecting a Keyboard to the Local Keyboard Port .....	4
Connecting Keyboards to the Remote Keyboard(s) Port .....	4
SWITCH SETTINGS .....	6
PROGRAMMING AND OPERATION .....	8
SPECIFICATIONS .....	10
INDEX .....	11
WARRANTY AND RETURN INFORMATION .....	12

## LIST OF ILLUSTRATIONS

1	KBD100 Application .....	3
2	Keyboard Cabling Diagram .....	5
3	Wiring Diagram for Remote Keyboards .....	5
4	Keyboard Rear Panel .....	7
5	Keyboard Functions .....	9

## LIST OF TABLES

A	KBD100 Operational Functions .....	3
B	Keyboard Addresses .....	6
C	Keyboard Definitions for KBD100 .....	8
D	KBD100 Button Functions .....	9

### REGULATORY NOTICES

Note: This equipment has been tested and found to comply with the limits of a Class A digital device, pursuant to part 15 of the FCC rules. These limits are designed to provide reasonable protection against harmful interference when the equipment is operated in a commercial environment. This equipment generates, uses, and can radiate radio frequency energy and, if not installed and used in accordance with the instruction manual, may cause harmful interference to radio communications. Operation of this equipment in a residential area is likely to cause harmful interference in which case the user will be required to correct the interference at his own expense.

# IMPORTANT SAFEGUARDS AND WARNINGS

Prior to installation and use of this product, the following WARNINGS should be observed.

1. Installation and servicing should only be done by qualified service personnel and conform to all local codes.
2. This unit is designed for indoor use only and must not be installed where exposed to rain and moisture.
3. Use only replacement parts recommended by Pelco.
4. After replacement/repair of this unit's electrical components, conduct a resistance measurement between line and exposed parts to verify the exposed parts have not been connected to line circuitry.

Please thoroughly familiarize yourself with the information in this manual prior to installation and operation.

## DESCRIPTION

The KBD100 Universal Keyboard is used to program and operate a CM6700 Matrix Switcher/Controller Unit (SCU).

The KBD100 provides economical system control and programming capability to locations that do not require the complete camera control abilities of the KBD200 and KBD300 Series keyboards. Table A lists the operational functions of the KBD100 keyboard.

**Table A.** KBD100 Operational Functions

Function	Availability
Select cameras	Yes
Select monitors	Yes
Control lenses	No
Set and call presets/patterns	No
Control receiver auxiliaries	No
Control switcher auxiliaries	Yes
Control multiplexer	No
Control CM6700 Matrix Switcher	Yes
Program CM6700 Matrix Switcher	Yes
Sequencing	Yes
Operate frame, auto, and random scans	No

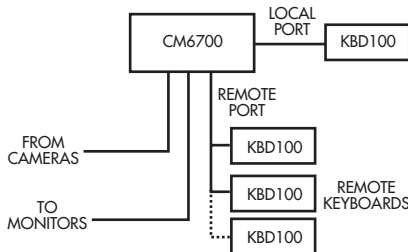

**Figure 1.** KBD100 Application

## INSTALLATION

There are two keyboard ports on the CM6700 Switcher/Control Unit (SCU).

The LOCAL KEYBOARD port is for connecting a single keyboard within a distance of 25 feet (7.6 meters).

The REMOTE KEYBOARD(S) port is for connecting additional remote keyboards.

### Connecting a Keyboard to the Local Keyboard Port

- 1 Use the data cable that is supplied with the keyboard. Plug one end of the cable into the RJ-45 connector on the rear of the keyboard and the other end into the LOCAL KEYBOARD port on the SCU (refer to Figure 2). Set the keyboard address according to Table B on page 6.

Go to step 2 to install remote keyboards, or go to step 10.

### Connecting Keyboards to the Remote Keyboard(s) Port

**NOTE:** A KBDKIT or KBDKIT-X is required for this application. The KBDKIT consists of two RJ-45 wall blocks and 120 VAC to 12 VAC transformers. The KBDKIT-X is for 230 VAC. Use one wall block for each keyboard.

Refer to Figures 2 and 3 for the following steps.

- 2 Select a suitable location for each keyboard and wall block. Wall blocks must be within 6 feet (1.8 m) of a suitable electrical outlet. Do not mount the wall block yet.
- 3 Run wall block interconnect cable (user-supplied) from the SCU to the closest keyboard location, then to the next nearest location, and the next, etc.

Communication to the keyboards is RS-485. Maximum cable distance for RS-485 communication over 24-gauge wire is 4,000 feet (1,219 m). Pelco recommends using shielded twisted pairs cable that meets or exceeds the basic requirements for EIA RS-485 applications.

- 4 Remove the wall block cover and make cable connections at each wall block according to Figure 3.
- 5 At each wall block, wire the transformer to pins 3 and 4. Polarity is unimportant.
- 6 Replace the cover on the wall block. Secure the wall block to a suitable surface. A double-sided sticky pad is provided to mount the wall block.
- 7 Set the address switches for each keyboard according to the instructions on page 6.
- 8 Plug in all keyboard data cables according to Figure 2.
- 9 Plug the KBDKIT or KBDKIT-X transformers into a suitable outlet.
- 10 To initialize the keyboard, wait five seconds after power-up, enter the number for the monitor you are viewing (1-4), and press MON. The LED display shows the number selected.

**NOTE:** You must re-initialize whenever power is cycled.

- 11 Go to the *Programming and Operation* Section and program and test for proper operation.

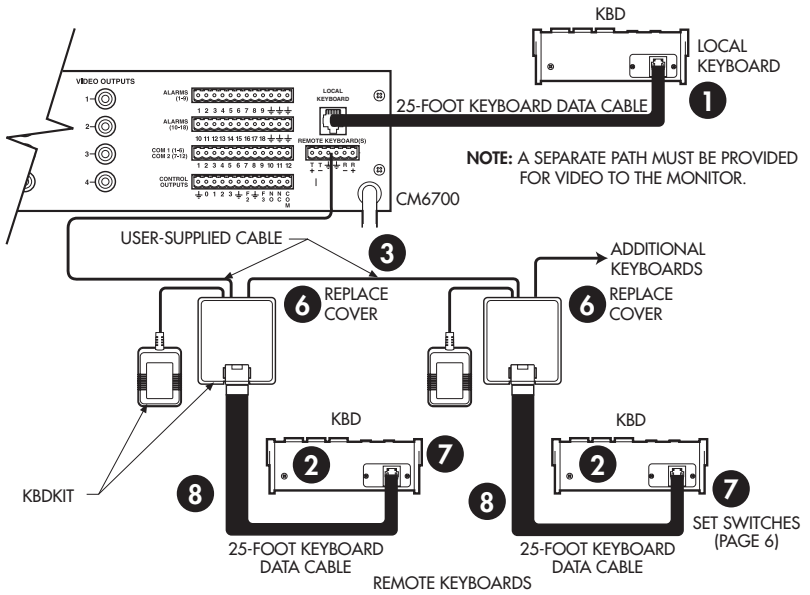

Figure 2. Keyboard Cabling Diagram

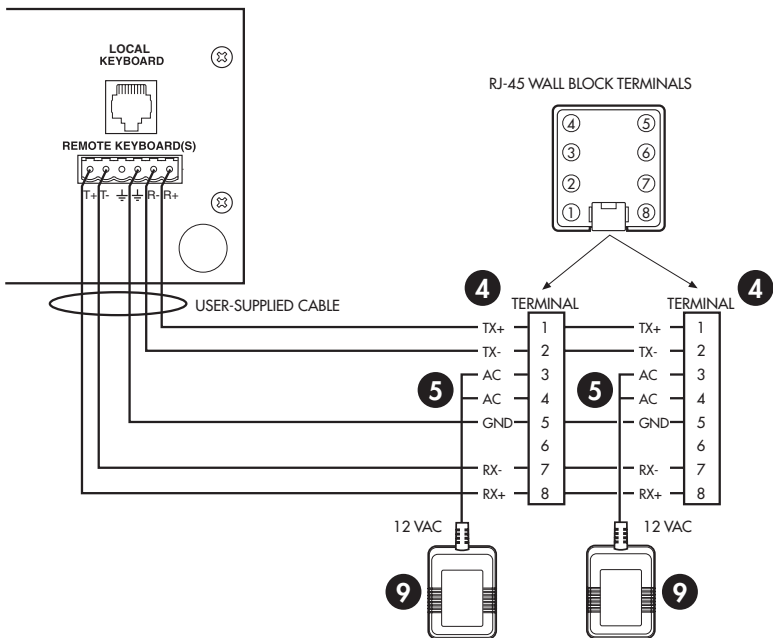

Figure 3. Wiring Diagram for Remote Keyboards

## SWITCH SETTINGS

To set the switches on the keyboard (refer to Figure 4):

❶ Remove the two screws and the DIP switch cover plate from the rear of the keyboard.

❷ Set the switches:

Address (Switches 1-4)

Position the switches according to Table B. Each keyboard in the system must have a different address. To make programming easier, address keyboards in ascending order.

**NOTE:** You may use a total of 8 different addresses between 1 and 16 with the CM6700 SCU.

Table B. Keyboard Addresses

Keyboard	Address	Switch Settings			
		1	2	3	4
1	0	OFF	OFF	OFF	OFF
2	1	ON	OFF	OFF	OFF
3	2	OFF	ON	OFF	OFF
4	3	ON	ON	OFF	OFF
5	4	OFF	OFF	ON	OFF
6	5	ON	OFF	ON	OFF
7	6	OFF	ON	ON	OFF
8	7	ON	ON	ON	OFF
9	8	OFF	OFF	OFF	ON
10	9	ON	OFF	OFF	ON
11	10	OFF	ON	OFF	ON
12	11	ON	ON	OFF	ON
13	12	OFF	OFF	ON	ON
14	13	ON	OFF	ON	ON
15	14	OFF	ON	ON	ON
16	15	ON	ON	ON	ON

❸ Replace the cover plate.

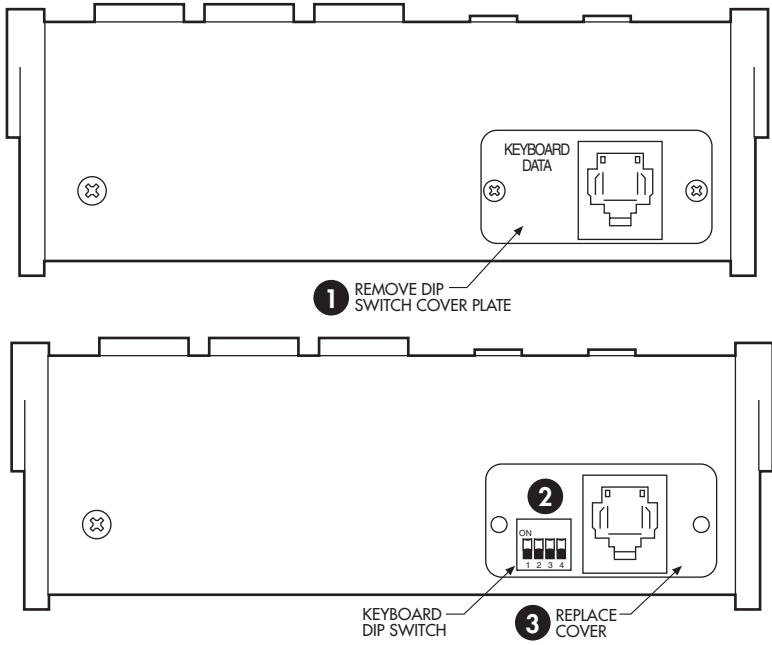

**Figure 4. Keyboard Rear Panel**

## PROGRAMMING AND OPERATION

Programming and operation of each function is explained in Tables C and D. Refer to Figure 5 for the location of keys.

**Table C.** Keyboard Definitions for KBD100

Function	Procedure
Select Camera	Enter camera number (1-16) <b>8</b> and press CAM <b>7</b> to select.  <b>NOTE:</b> <i>The CM6700 can be programmed to restrict some monitors from viewing certain cameras. To display a camera's view on your monitor, be sure that your keyboard shows the number of the monitor you are viewing and be sure that the CM6700 has not been programmed to restrict viewing of that camera.</i>
Select Monitor	LED display <b>1</b> shows monitor number in run mode. Enter monitor number (1-4) <b>8</b> and press MON <b>10</b> to select.
Sequence	Sequence steps through all 16 cameras. Camera number, camera title, sequence status, and time/date are shown on the monitor. Press PREV <b>2A</b> to step back one camera. Hold for two seconds for a backward sequence. Monitor shows <b>B</b> . Press during sequence to speed up. Press during a forward sequence to reverse. Press NEXT <b>2B</b> to step forward one camera. Hold for two seconds for a forward sequence. Monitor shows <b>F</b> . Press during sequence to speed up. Press during a backward sequence to go forward. Press HOLD <b>2C</b> to hold a sequence. Monitor shows <b>H</b> . Press PREV or NEXT to resume. Manually select a camera or press CAM <b>7</b> to turn off a sequence. Monitor shows <b>O</b> .
Macro Sequence	Enter 1 or 2 <b>8</b> and press MACRO <b>5</b> to start a group camera sequence. Monitor shows <b>M</b> . Refer to the CM6700 manual for macro/sequence programming.
Auxiliaries/Relays	F1-F3 <b>3</b> control only the auxiliaries built into the CM6700 SCU. These outputs can be programmed for momentary, keyed, latched, or alarm operation. See the CM6700 SCU manual for programming instructions. F1: Activate/deactivate switcher auxiliary 1 relay. F2: Activate/deactivate switcher auxiliary 2 TTL output. F3: Activate/deactivate switcher auxiliary 3 TTL output.
Acknowledge Alarm	Press ACK <b>9</b> to acknowledge an alarm. Refer to the CM6700 manual for further information on alarms.
Program (CM6700)	To program the CM6700 switcher, press PGM <b>4</b> . Follow the programming procedure in the CM6700 manual. LED Display <b>1</b> shows P in program mode. Press ACK <b>9</b> to exit.
LED	LED <b>1</b> shows monitor number or P (in program mode).
Clear	Press CLEAR <b>6</b> to cancel a number that has been entered.



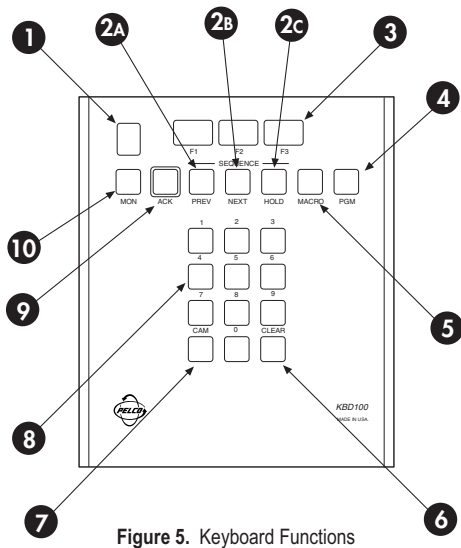

Figure 5. Keyboard Functions

Table D. KBD100 Button Functions

Reference Number	Description
1	LED display
2A-2C	Sequence keys: Previous, Next, Hold
3	Function keys F1, F2, F3 control auxiliaries
4	Program key
5	Macro sequence key
6	Clear key
7	Camera selection key
8	Keypad (numbers 1 through 0)
9	Acknowledge key
10	Monitor selection key

# SPECIFICATIONS

## **GENERAL**

Keyboard Keypad:	Electromechanical
Digital Display:	Red LED, 7-segment, 2 cells
Ambient Operating Temperature:	20° to 120°F (-7° to 49°C)
Humidity:	10-90% non-condensing
Dimensions:	6.00 (W) x 7.125 (D) x 2.25 (H) inches (15.24 x 18.10 x 5.72 cm)
Weight:	1.9 lb (0.86 kg)

## **ELECTRICAL**

Input Voltage:	12 VAC or $\pm 12$ VDC
Power Consumption:	5 watts
Connector Type:	RJ-45, 8-pin modular (female)

### Keyboard Communication

Interface:	RS-485
Protocol:	Pelco ASCII
Baud:	9600

Communication Parameters: 8 data bits, odd parity, 1 stop bit

(Design and product specifications subject to change without notice.)



This equipment contains electrical or electronic components that must be recycled properly to comply with Directive 2002/96/EC of the European Union regarding the disposal of waste electrical and electronic equipment (WEEE). Contact your local dealer for procedures for recycling equipment.

# INDEX

## A

Acknowledge Alarm 8  
Auxiliaries 8

## C

Clear 8

## D

Description 3  
DIP switch 6

## I

Installation 4

## K

KBDKIT 4  
KBDKIT-X 4  
Keyboard Addresses 6

## L

LED 8

## M

Macro Sequence 8

## O

Operation 8  
Operation functions 8

## P

Program CM6700 8  
Programming 8

## R

Regulatory notices 2  
Relays 8  
Returns 12  
RS-485 cable distance 4

## S

Safeguards 3  
Select Camera 8  
Select Monitor 8  
Sequence 8  
Specifications 10  
Switch Settings 6

## W

Wall block 4  
Warranty 12

# WARRANTY AND RETURN INFORMATION

## WARRANTY

Pelco will repair or replace, without charge, any merchandise proved defective in material or workmanship for a period of one year after the date of shipment.

Exceptions to this warranty are as noted below:

- Five years on FT/FR8000 Series fiber optic products.
- Three years on Genex® Series products (multiplexers, server, and keyboard).
- Three years on Camclosure® and fixed camera models, except the CC3701H-2, CC3701H-2X, CC3751H-2, CC3651H-2X, MC3651H-2, and MC3651H-2X camera models, which have a five-year warranty.
- Two years on standard motorized or fixed focal length lenses.
- Two years on Legacy®, CM6700/CM6800/CM9700 Series matrix, and DF5/DF8 Series fixed dome products.
- Two years on Spectra®, Esprit®, ExSite™, and PS20 scanners, including when used in continuous motion applications.
- Two years on Esprit® and WW5700 Series window wiper (excluding wiper blades).
- Eighteen months on DX Series digital video recorders, NVR300 Series network video recorders, and Endura™ Series distributed network-based video products.
- One year (except video heads) on video cassette recorders (VCRs). Video heads will be covered for a period of six months.
- Six months on all pan and tilts, scanners or preset lenses used in continuous motion applications (that is, preset scan, tour and auto scan modes).

Pelco will warrant all replacement parts and repairs for 90 days from the date of Pelco shipment. All goods requiring warranty repair shall be sent freight prepaid to Pelco, Clovis, California. Repairs made necessary by reason of misuse, alteration, normal wear, or accident are not covered under this warranty.

Pelco assumes no risk and shall be subject to no liability for damages or loss resulting from the specific use or application made of the Products. Pelco's liability for any claim, whether based on breach of contract, negligence, infringement of any rights of any party or product liability, relating to the Products shall not exceed the price paid by the Dealer to Pelco for such Products. In no event will Pelco be liable for any special, incidental or consequential damages (including loss of use, loss of profit and claims of third parties) however caused, whether by the negligence of Pelco or otherwise.

The above warranty provides the Dealer with specific legal rights. The Dealer may also have additional rights, which are subject to variation from state to state.

If a warranty repair is required, the Dealer must contact Pelco at (800) 289-9100 or (559) 292-1981 to obtain a Repair Authorization number (RA), and provide the following information:

1. Model and serial number
2. Date of shipment, P.O. number, Sales Order number, or Pelco invoice number
3. Details of the defect or problem

If there is a dispute regarding the warranty of a product which does not fall under the warranty conditions stated above, please include a written explanation with the product when returned.

Method of return shipment shall be the same or equal to the method by which the item was received by Pelco.

## RETURNS

In order to expedite parts returned to the factory for repair or credit, please call the factory at (800) 289-9100 or (559) 292-1981 to obtain an authorization number (CA number if returned for credit, and RA number if returned for repair).

All merchandise returned for credit may be subject to a 20% restocking and refurbishing charge.

Goods returned for repair or credit should be clearly identified with the assigned CA or RA number and freight should be prepaid. Ship to the appropriate address below.

If you are located within the continental U.S., Alaska, Hawaii or Puerto Rico, send goods to:

Service Department  
Pelco  
3500 Pelco Way  
Clovis, CA 93612-5699

If you are located outside the continental U.S., Alaska, Hawaii or Puerto Rico and are instructed to return goods to the USA, you may do one of the following:

If the goods are to be sent by a COURIER SERVICE, send the goods to:

Pelco  
3500 Pelco Way  
Clovis, CA 93612-5699 USA

If the goods are to be sent by a FREIGHT FORWARDER, send the goods to:

Pelco c/o Expeditors  
473 Eccles Avenue  
South San Francisco, CA 94080 USA  
Phone: 650-737-1700  
Fax: 650-737-0933

Pelco, the Pelco logo, Camclosure, Esprit, Genex, Legacy, and Spectra are registered trademarks of Pelco.  
Endura and ExSite are trademarks of Pelco.  
© Copyright 2000, Pelco. All rights reserved.

## REVISION HISTORY

Manual #	Date	Comments
C529M	7/97	Original version.
C529M-A	12/97	Revision a. Revised installation instructions.
C529M-B	5/98	Revised installation instructions as a result of hardware changes to the rear panel of the CM6700 SCU. Removed references to KBD100-X because model has been replaced with KBDKIT-X. Changed manual pagination.
	6/98	Added Section 1.2, Regulatory Notices and Section 2.2, Certifications.
	10/98	Revised Table A.
C529M-C	8/00	Revised format.
C529M-D	9/03	Added uL certification seal. Changed power consumption specification.